

EGO-STATES ERIC BERNE

Berne said:

- we have all by definition had at least 1 person in loco parentis to be here -
- we've all had a past
- we can discriminate between what's happening now and memory and distinguish between what's happening inside and outside

The ego-state brings together thinking, feeling and behaviour

P

Parent - think, feel and act - modelling the way someone took care of us

A

Adult - ability to notice and stay in contact with the here and now

C

Child - bring the past into now - 'regression' if staying in the past

P

Parent - borrowed

A

Adult - here and now

C

Child - old

- all 3 present and we can change from one to the other - in dramatic situations 1 dominates
- an healthy person dissolves and integrates all three

FINDING YOUR EGO-STATES

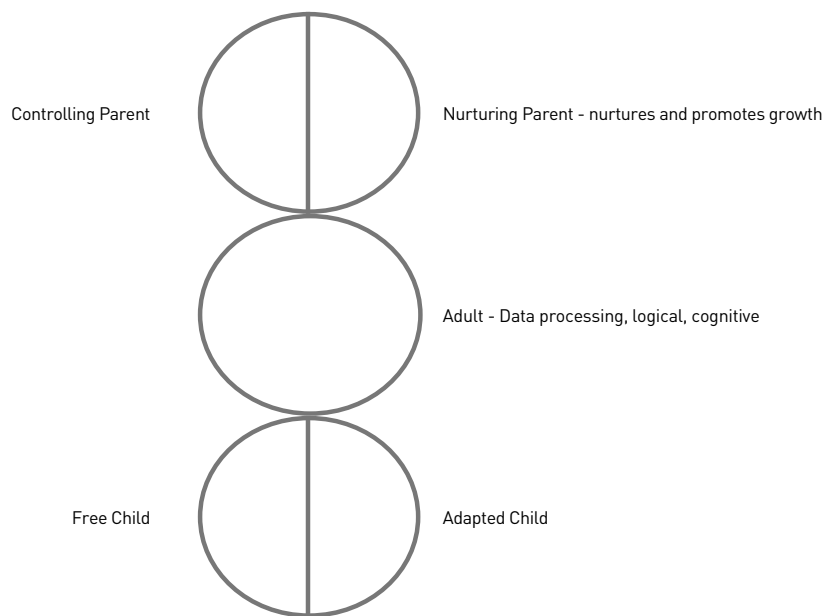

	Recent time when you took care of someone	Recent time when you made someone do something you wanted them to	What do you do when you have to undertake a project?	What do you do when you want to get noticed?	What do you do to have fun?
	NP	CP	A	AC	FC
thoughts					
feelings					
behaviours					
physical					

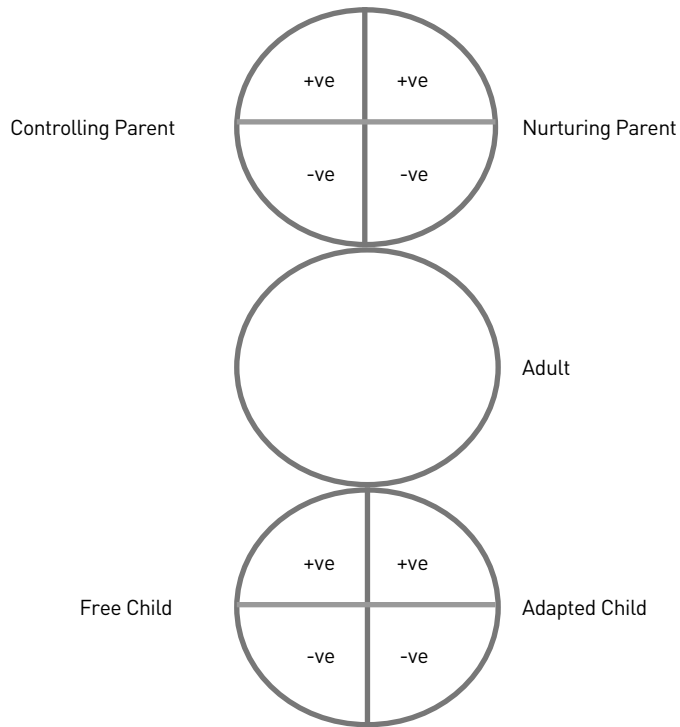

BERNE'S THREE TYPES OF TRANSACTION AND THE RULES OF TRANSACTION

1 COMPLEMENTARY

Rules of communication one

Communication carries on indefinitely

The transaction is directed to an ego state in the other who responds using the same ego state.

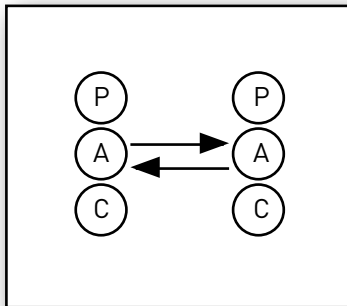

A what time is it?

A five past two

C give it back it's mine

C no it's not it's mine

or

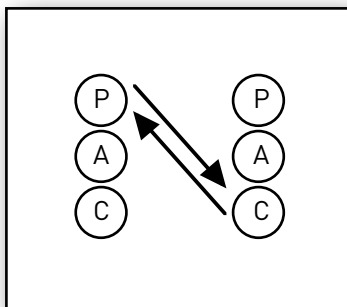

2 CROSSED

Rules of communication two

When transactions are crossed then communication is broken

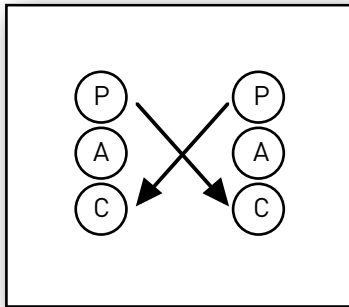

- P Go to bed
- C stop shouting think of your heart

Closed if respondent uses a different ego state to the one you are responding to

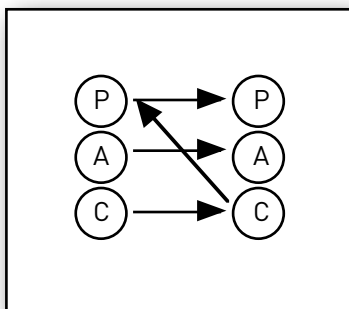

By crossing you maximise the chance of something different happening.

Communication is an invitation.

3 ULTERIOR

Rules of communication three

Behavioural outcome of an ulterior transaction is determined at the psychological level

Two ego-states at the same time - incongruent communication, verbal different to non-verbal

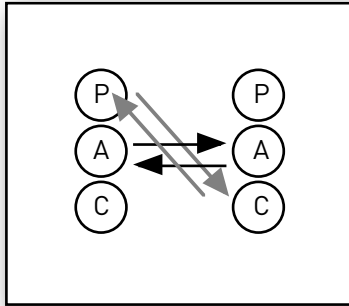

One is at the Social Level and the ulterior is at the psychological.

Characteristics of an Ulterior Transaction

- unconscious - if brought to the conscious it is hard to do
- trying to maintain it when there is no response is very draining
- outside of awareness